

KEY FEATURES

- 2-way compact speaker system
- two 6" carbon fiber woofers
- horn loaded titanium dome 1" exit tweeter
- 70° x 70° constant directivity horn
- LICC (Low Impedance Compensated Crossover) network
- HF dynamic protection
- two Speakon NL4MP input connectors
- trapezoidal box shape
- 19 mm multilayered birch box construction
- black scratchproof paint finishing
- metal protective grille
- M10 & M8 suspension inserts
(to be used with PA-A6 and PA-A8 optional accessory or Omnimount 100 series)

DESCRIPTION

The PA 261 VISION speaker system is dedicated for high quality audio installation systems. The specific electro-acoustic project have been optimized in order to achieve an high intelligibility even in the most difficult environment situations.

LICC advanced crossover network ensures the lowest phase rotation possible in a passive network, using low inductance values with the best transient response.

The box, made in 19 mm multilayered birch finished with black scratchproof paint, is ready to be suspended via M10 inserts, using our optional wall mounting bracket PA-A6, or via M8 inserts using a world-standard Omnimount 100 series standard accessory (not provided).

A standard 35 mm stand could be used in conjunction with our PA-A8 adaptor.

VISION PA 261

Ordering code 131.10.184

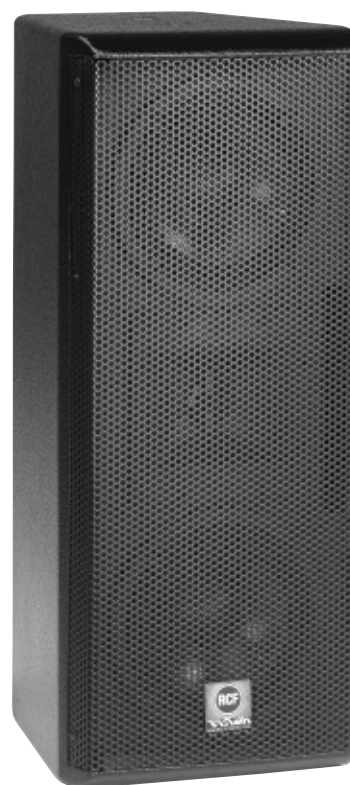

TECHNICAL DATA

ELECTROACOUSTIC SPECIFICATIONS

Topology	2-way bass reflex speaker system
RMS power handling	200 W
Peak power handling	600 W
Nominal Impedance	8 Ohm
Transducers	LF: 2 x 6" carbon fiber woofers HF: 1" exit horn-loaded titanium tweeter
HF Horn type	Constant Directivity - built-in phase plug
Coverage pattern (-6 dB)	70° x 70°
Frequency Response (±3 dB)	60 Hz - 15 kHz
Sensitivity (1W / 1mt)	91 dB
Max SPL (1 mt)	117 dB
Crossover	2 kHz
HF protection	dynamic
Connectors	two NL4MP Speakon

CABINET SPECIFICATIONS

Wood	19-mm multilayered birch
Finishing	black painting
Handles	two
Rigging hardware	5 x M10 - 4 x M8 insert points
Dimensions (H x W x D)	610 x 255 x 291 mm
Internal volume	23.5 l
Net weight	17 kg



DIMENSIONAL DRAWING

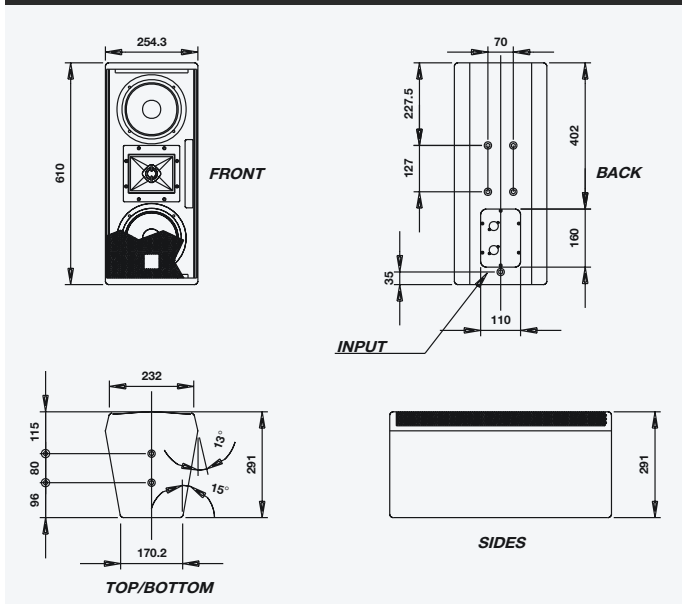

STANDARD SETUP

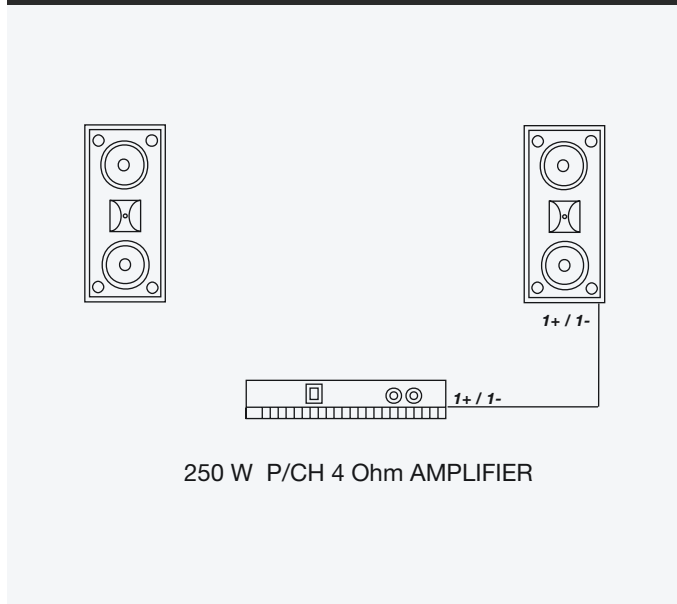

OPTIONAL ACCESSORIES

PA-A1	standard M10 fish-eye with customized adaptor	ordering code 133.20.096
PA-A6	adjustable mounting bracket	ordering code 133.20.018
PA-A8	35 mm stand mounting adaptor	ordering code 133.20.020
DP 260	2-in 6-out 20 bit digital speaker management system	ordering code 121.70.001

VISION 261 APPLICATION GUIDE

- Auditoriums
- Convention Centres
- A/V presentation
- Vocal-only reinforcement
- Houses of worship
- Theaters



A MACKIE DESIGNS INC. COMPANY www.mackie.com

RCF S.p.A.

Via G. Ferraris 2 • 42029 S. Maurizio (Reggio Emilia) • ITALY • Tel. +39 0522.354111 • Fax +39 0522.551875
 Internet: <http://www.rcf.it> • E-mail: rcfspa@rcf.it