

MODEL 110B LOUDSPEAKER

Applications:

- Supermarkets, Retail Stores
- Factories
- Warehouses
- Courtrooms
- Classrooms and Other Educational Facilities
- Stadium or Arena Concourses, Gift Shops and Rest Rooms
- Airports and Transportation Centers
- Office Building Reception Areas
- Restaurants
- Casinos
- Shopping Center Common Areas / Food Courts
- Anywhere background music and articulate voice announcements are required

For Installations Requiring:

- Clear Voice Announcements
- Even, Omnidirectional Coverage
- Seamless Background Music
- Fast Distributed System Installation
- Compact, Unobtrusive Speakers

Features:

- Hemispherical Coverage Pattern
- Articulate Voice Announcements
- Light Weight Enables Many Varied Mounting Possibilities
- Fully Assembled and Ready to Mount
- Hanging or Surface Mount
- Standard and Custom Colors Available

Specifications:

Sensitivity	92dB SPL 1W/1m
Maximum SPL	107dB SPL 30W/1m
Power Handling	35 Watts
Frequency Response	70Hz to 12kHz ±6dB
Coverage	180° vertical 360° horizontal
Rated Impedance	4 ohms
Weight	8 lbs. (3.6 kg)
Size	Height: 11 7/8" (302mm) Sphere Diameter: 10" (254mm) Reflector Diameter: 14 7/8" (378mm)
Driver	Dual Cone 6 1/2"
Material	Enclosure and reflector are structural foam polystyrene with rustproof hardware

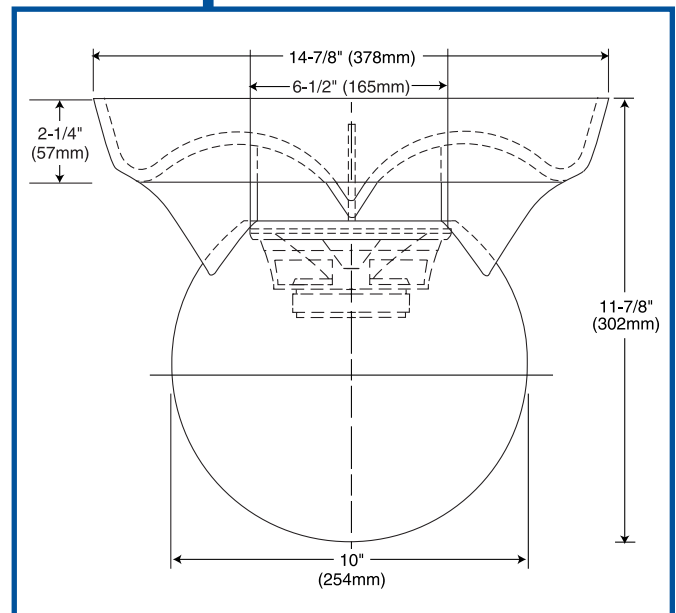

SOUNDSPHERE®

Division of Sonic Systems, Inc.

10 Research Drive, Stratford, CT 06615

(203) 386-9200 • Fax: (203) 386-0773 • Web: www.soundsphere.com

Request document AN-110B for detailed application information, or log on to www.soundsphere.com for EASE database download, more detailed information, or to learn about other Soundsphere products.

Accessories

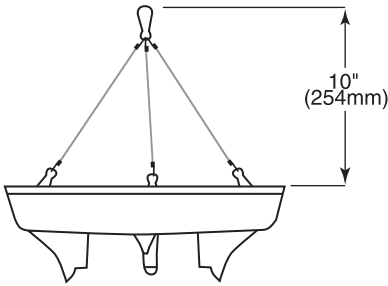

Hanging Kit — Order No. 110HK

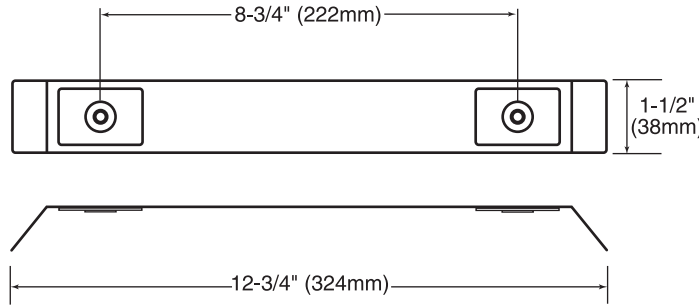

Mounting Bracket — Order No. 110MB
for mounting speaker on a flat surface

Beam Clip — Order No. SSBC
Locates a 1/4" hole on a 1/8" to 1/4" beam flange using just a hammer.



Drop Ceiling Bracket — Order No. 110DCB
Two twist clips and 110MB are supplied. Clips twist onto t-bar stringers, and mounting bracket attaches with wing nuts.

Line Matching Transformer — Order No. TX-30

The Model TX-30 is a 30 Watt line matching transformer for the Model 110B with taps for 25, 50, 70, and 100 Volt constant voltage systems. The TX-30 is designed for factory or field mounting in the 110B reflector. Connection to system wiring is via 10" color coded flying leads. Available taps: 25 Volt: 30, 15, 7.5, 3.8, 1.9, 1.0, 0.5 Watts; 50 Volt: 30, 15, 7.5, 3.8, 1.9 Watts; 70 Volt: 30, 15, 7.5, 3.8 Watts; 100 Volt: 30, 15, 7.5 Watts.

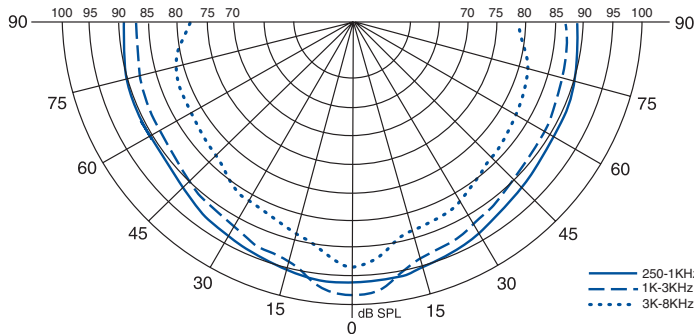

Vertical Polar Response

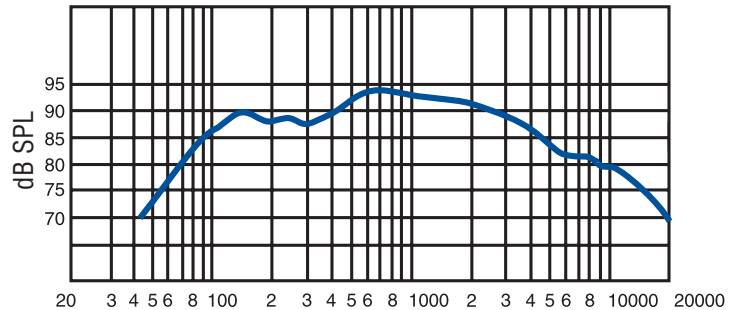

Hemispherical Frequency Response 1W/1m

Architects and Engineers Specifications

The loudspeaker shall be a self-contained, wide-range device with a wide coverage pattern. The frequency response shall be 70Hz to 12kHz ± 6 dB; the vertical polar coverage shall be $180^\circ \pm 6$ dB.

The loudspeaker shall have a minimum sensitivity of 92dB SPL 1 Watt/1 meter, a continuous power handling capability of 35 Watts RMS, and a rated impedance of 4 ohms.

The loudspeaker driver shall be one 6½ inch full range unit. The driver shall be mounted in a spherical enclosure made of structural foam polystyrene. Assembly hardware shall be rustproof. Optional mounting kits are available: a bracket to mount flat against a ceiling surface, or a three-element hanging kit for single point suspension.

The enclosure and reflector color shall be ordered in advance, otherwise white shall be supplied. The loudspeaker shall be comprised of a 14 7/8 inch (378mm) diameter reflector mounted to a 10 inch (254mm) diameter sphere. The complete loudspeaker shall be 11 7/8 (302mm) inches in overall height and weigh 8 lbs. (3.6kg). The loudspeaker shall be the Soundsphere Model 110B.

Warranty

Soundsphere® loudspeakers are warranted against failure or malfunction due to defects in materials or workmanship for a period of five years from date of original purchase. Defective units will be repaired or replaced at our option if delivered prepaid to our factory. Repaired or replaced units will be returned at our expense. Warranty does not cover appearance or damage caused by abuse, misuse, neglect, accident, or exceeding maximum rated power. Warranty does not cover labor costs involved in removing and/or reinstalling the defective unit, nor any liability due to accidents caused by improper installation. Warranty is extended to original purchaser and is not transferable.